



Full wwPDB X-ray Structure Validation Report ⓘ

Jun 24, 2024 – 09:30 AM EDT

PDB ID : 6I8S
Title : Discovery and characterisation of an antibody that selectively modulates the inhibitory activity of plasminogen activator inhibitor-1
Authors : Vousden, K.A.; Lundqvist, T.; Popovic, B.
Deposited on : 2018-11-21
Resolution : 2.90 Å(reported)

This is a Full wwPDB X-ray Structure Validation Report for a publicly released PDB entry.

We welcome your comments at validation@mail.wwpdb.org

A user guide is available at

<https://www.wwpdb.org/validation/2017/XrayValidationReportHelp>

with specific help available everywhere you see the ⓘ symbol.

The types of validation reports are described at

<http://www.wwpdb.org/validation/2017/FAQs#types>.

The following versions of software and data (see [references ⓘ](#)) were used in the production of this report:

MolProbity : 4.02b-467
Xtriage (Phenix) : 1.13
EDS : 2.37.1
Percentile statistics : 20191225.v01 (using entries in the PDB archive December 25th 2019)
Refmac : 5.8.0158
CCP4 : 7.0.044 (Gargrove)
Ideal geometry (proteins) : Engh & Huber (2001)
Ideal geometry (DNA, RNA) : Parkinson et al. (1996)
Validation Pipeline (wwPDB-VP) : 2.37.1

1 Overall quality at a glance i

The following experimental techniques were used to determine the structure:

X-RAY DIFFRACTION

The reported resolution of this entry is 2.90 Å.

Percentile scores (ranging between 0-100) for global validation metrics of the entry are shown in the following graphic. The table shows the number of entries on which the scores are based.

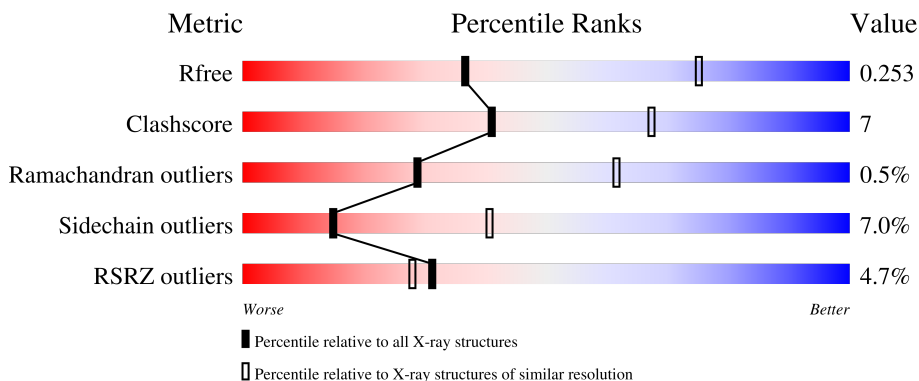

Metric	Whole archive (#Entries)	Similar resolution (#Entries, resolution range(Å))
R_{free}	130704	1957 (2.90-2.90)
Clashscore	141614	2172 (2.90-2.90)
Ramachandran outliers	138981	2115 (2.90-2.90)
Sidechain outliers	138945	2117 (2.90-2.90)
RSRZ outliers	127900	1906 (2.90-2.90)

The table below summarises the geometric issues observed across the polymeric chains and their fit to the electron density. The red, orange, yellow and green segments of the lower bar indicate the fraction of residues that contain outliers for ≥ 3 , 2, 1 and 0 types of geometric quality criteria respectively. A grey segment represents the fraction of residues that are not modelled. The numeric value for each fraction is indicated below the corresponding segment, with a dot representing fractions $\leq 5\%$. The upper red bar (where present) indicates the fraction of residues that have poor fit to the electron density. The numeric value is given above the bar.

Mol	Chain	Length	Quality of chain
1	A	379	<div style="display: flex; align-items: center;"> <div style="width: 3%; height: 10px; background-color: red; margin-right: 5px;"></div> <div style="width: 82%; height: 10px; background-color: green; margin-right: 5px;"></div> <div style="width: 13%; height: 10px; background-color: yellow; margin-right: 5px;"></div> <div style="width: 2%; height: 10px; background-color: orange; margin-right: 5px;"></div> <div style="width: 2%; height: 10px; background-color: grey;"></div> </div> <p style="text-align: center;">3% 82% 13% . .</p>
1	B	379	<div style="display: flex; align-items: center;"> <div style="width: 5%; height: 10px; background-color: red; margin-right: 5px;"></div> <div style="width: 81%; height: 10px; background-color: green; margin-right: 5px;"></div> <div style="width: 14%; height: 10px; background-color: yellow; margin-right: 5px;"></div> <div style="width: 2%; height: 10px; background-color: orange; margin-right: 5px;"></div> <div style="width: 2%; height: 10px; background-color: grey;"></div> </div> <p style="text-align: center;">5% 81% 14% . .</p>
1	C	379	<div style="display: flex; align-items: center;"> <div style="width: 4%; height: 10px; background-color: red; margin-right: 5px;"></div> <div style="width: 80%; height: 10px; background-color: green; margin-right: 5px;"></div> <div style="width: 15%; height: 10px; background-color: yellow; margin-right: 5px;"></div> <div style="width: 2%; height: 10px; background-color: orange; margin-right: 5px;"></div> <div style="width: 2%; height: 10px; background-color: grey;"></div> </div> <p style="text-align: center;">4% 80% 15% . .</p>
1	D	379	<div style="display: flex; align-items: center;"> <div style="width: 10%; height: 10px; background-color: red; margin-right: 5px;"></div> <div style="width: 77%; height: 10px; background-color: green; margin-right: 5px;"></div> <div style="width: 15%; height: 10px; background-color: yellow; margin-right: 5px;"></div> <div style="width: 2%; height: 10px; background-color: orange; margin-right: 5px;"></div> <div style="width: 2%; height: 10px; background-color: grey;"></div> </div> <p style="text-align: center;">10% 77% 15% . .</p>
2	E	223	<div style="display: flex; align-items: center;"> <div style="width: 6%; height: 10px; background-color: red; margin-right: 5px;"></div> <div style="width: 76%; height: 10px; background-color: green; margin-right: 5px;"></div> <div style="width: 17%; height: 10px; background-color: yellow; margin-right: 5px;"></div> <div style="width: 2%; height: 10px; background-color: orange; margin-right: 5px;"></div> <div style="width: 2%; height: 10px; background-color: grey;"></div> </div> <p style="text-align: center;">6% 76% 17% . .</p>

Continued on next page...

Continued from previous page...

Mol	Chain	Length	Quality of chain
2	F	223	<p>6% 65% 28% . .</p>
2	G	223	<p>3% 84% 11% . .</p>
2	H	223	<p>5% 83% 12% . .</p>
3	I	214	<p>2% 86% 10% . .</p>
3	J	214	<p>6% 75% 22% . .</p>
3	K	214	<p>0% 85% 13% . .</p>
3	L	214	<p>1% 90% 8% .</p>

2 Entry composition i

There are 4 unique types of molecules in this entry. The entry contains 24618 atoms, of which 0 are hydrogens and 0 are deuteriums.

In the tables below, the ZeroOcc column contains the number of atoms modelled with zero occupancy, the AltConf column contains the number of residues with at least one atom in alternate conformation and the Trace column contains the number of residues modelled with at most 2 atoms.

- Molecule 1 is a protein called Plasminogen activator inhibitor 1.

Mol	Chain	Residues	Atoms					ZeroOcc	AltConf	Trace
			Total	C	N	O	S			
1	A	363	2901	1862	495	529	15	0	0	0
1	B	363	2901	1862	495	529	15	0	0	0
1	C	363	2901	1862	495	529	15	0	0	0
1	D	363	2901	1862	495	529	15	0	0	0

There are 16 discrepancies between the modelled and reference sequences:

Chain	Residue	Modelled	Actual	Comment	Reference
A	150	HIS	ASN	engineered mutation	UNP P05121
A	154	THR	LYS	engineered mutation	UNP P05121
A	319	LEU	GLN	engineered mutation	UNP P05121
A	354	ILE	MET	engineered mutation	UNP P05121
B	150	HIS	ASN	engineered mutation	UNP P05121
B	154	THR	LYS	engineered mutation	UNP P05121
B	319	LEU	GLN	engineered mutation	UNP P05121
B	354	ILE	MET	engineered mutation	UNP P05121
C	150	HIS	ASN	engineered mutation	UNP P05121
C	154	THR	LYS	engineered mutation	UNP P05121
C	319	LEU	GLN	engineered mutation	UNP P05121
C	354	ILE	MET	engineered mutation	UNP P05121
D	150	HIS	ASN	engineered mutation	UNP P05121
D	154	THR	LYS	engineered mutation	UNP P05121
D	319	LEU	GLN	engineered mutation	UNP P05121
D	354	ILE	MET	engineered mutation	UNP P05121

- Molecule 2 is a protein called HEAVY CHAIN OF FAB FRAGMENT FROM AN PAI-1 ANTIBODY.

Mol	Chain	Residues	Atoms				ZeroOcc	AltConf	Trace	
2	E	214	Total 1614	C 1021	N 274	O 313	S 6	0	0	0
2	F	214	Total 1614	C 1021	N 274	O 313	S 6	0	0	0
2	G	214	Total 1614	C 1021	N 274	O 313	S 6	0	0	0
2	H	214	Total 1614	C 1021	N 274	O 313	S 6	0	0	0

- Molecule 3 is a protein called LIGHT CHAIN OF FAB FRAGMENT FROM AN PAI-1 ANTIBODY.

Mol	Chain	Residues	Atoms				ZeroOcc	AltConf	Trace	
3	I	211	Total 1628	C 1022	N 274	O 327	S 5	0	0	0
3	J	211	Total 1628	C 1022	N 274	O 327	S 5	0	0	0
3	K	211	Total 1628	C 1022	N 274	O 327	S 5	0	0	0
3	L	211	Total 1628	C 1022	N 274	O 327	S 5	0	0	0

- Molecule 4 is water.

Mol	Chain	Residues	Atoms	ZeroOcc	AltConf
4	A	6	Total 6 O 6	0	0
4	B	5	Total 5 O 5	0	0
4	C	7	Total 7 O 7	0	0
4	D	5	Total 5 O 5	0	0
4	F	2	Total 2 O 2	0	0
4	H	3	Total 3 O 3	0	0
4	I	4	Total 4 O 4	0	0
4	J	3	Total 3 O 3	0	0
4	K	7	Total 7 O 7	0	0

Continued on next page...

Continued from previous page...

Mol	Chain	Residues	Atoms		ZeroOcc	AltConf
4	L	4	Total	O	0	0
			4	4		

3 Residue-property plots [i](#)

These plots are drawn for all protein, RNA, DNA and oligosaccharide chains in the entry. The first graphic for a chain summarises the proportions of the various outlier classes displayed in the second graphic. The second graphic shows the sequence view annotated by issues in geometry and electron density. Residues are color-coded according to the number of geometric quality criteria for which they contain at least one outlier: green = 0, yellow = 1, orange = 2 and red = 3 or more. A red dot above a residue indicates a poor fit to the electron density ($RSRZ > 2$). Stretches of 2 or more consecutive residues without any outlier are shown as a green connector. Residues present in the sample, but not in the model, are shown in grey.

- Molecule 1: Plasminogen activator inhibitor 1

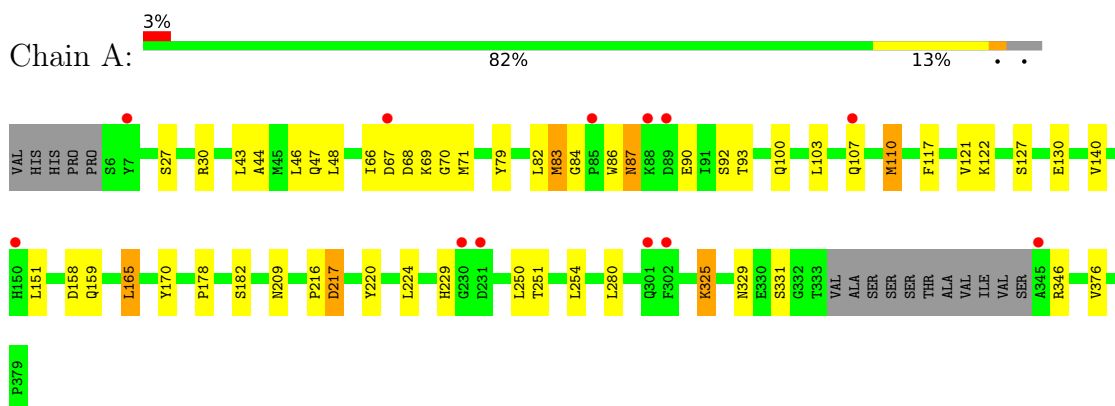

- Molecule 1: Plasminogen activator inhibitor 1

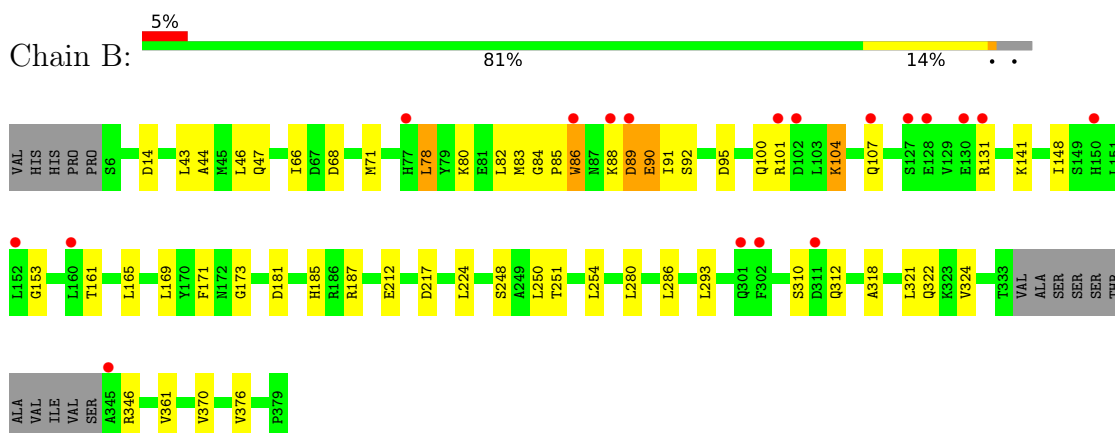

- Molecule 1: Plasminogen activator inhibitor 1

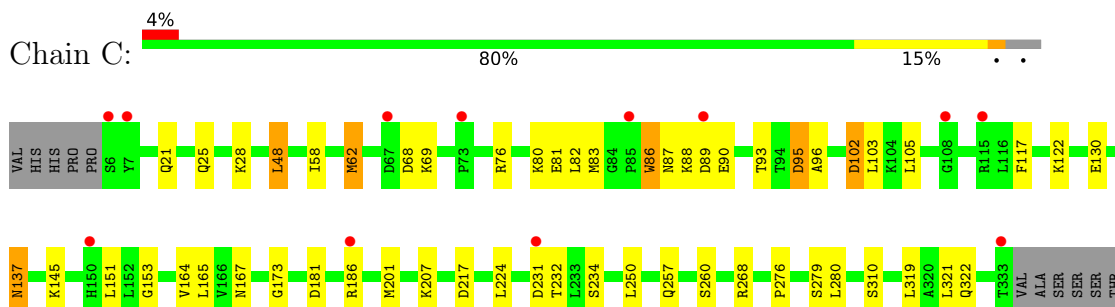

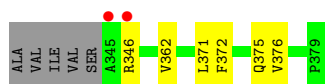

- Molecule 1: Plasminogen activator inhibitor 1

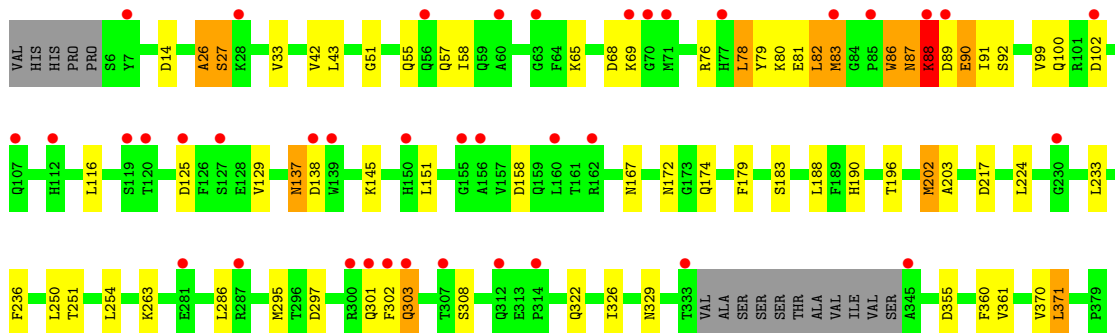
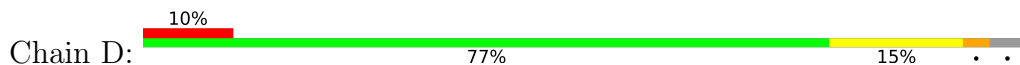

- Molecule 2: HEAVY CHAIN OF FAB FRAGMENT FROM AN PAI-1 ANTIBODY

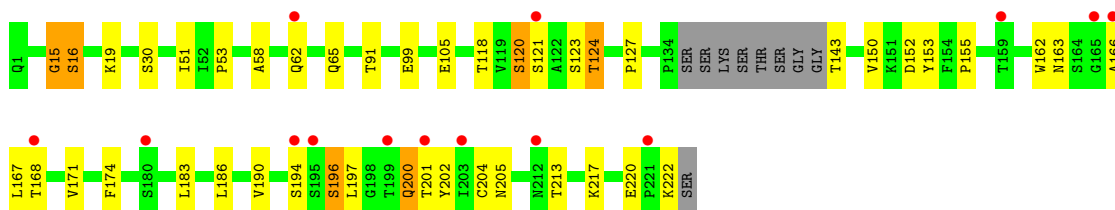
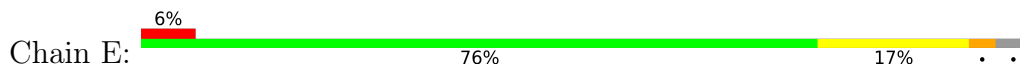

- Molecule 2: HEAVY CHAIN OF FAB FRAGMENT FROM AN PAI-1 ANTIBODY

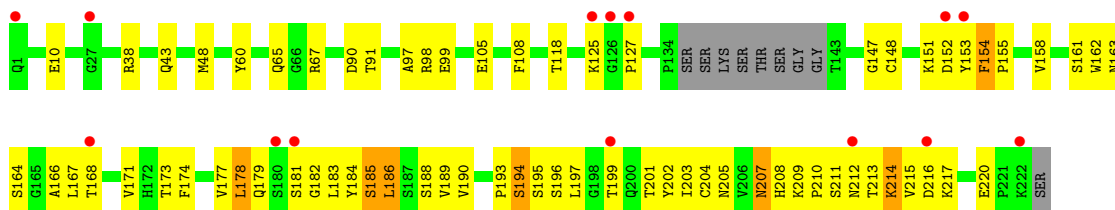

- Molecule 2: HEAVY CHAIN OF FAB FRAGMENT FROM AN PAI-1 ANTIBODY

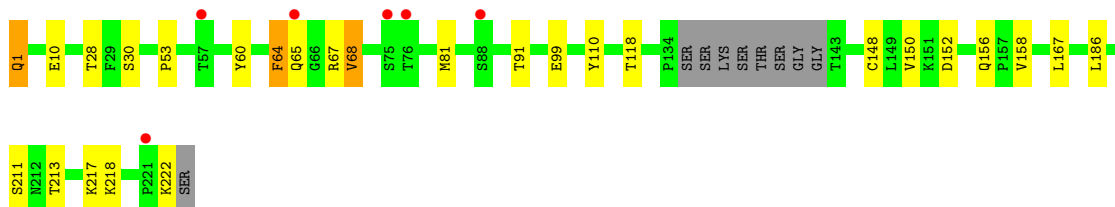
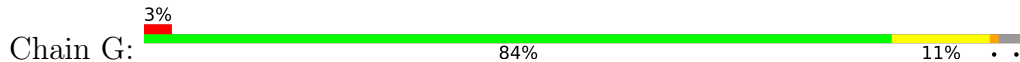

- Molecule 2: HEAVY CHAIN OF FAB FRAGMENT FROM AN PAI-1 ANTIBODY

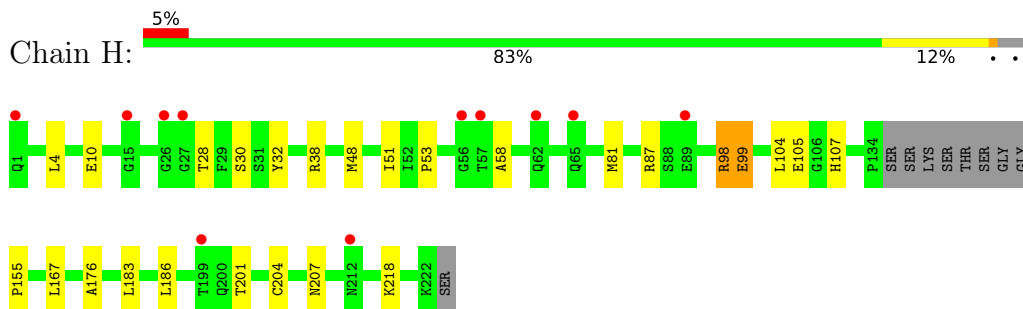

- Molecule 3: LIGHT CHAIN OF FAB FRAGMENT FROM AN PAI-1 ANTIBODY

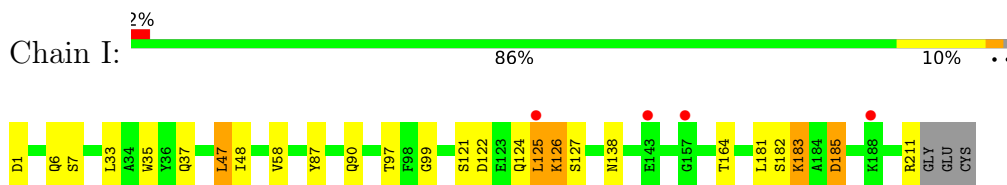

- Molecule 3: LIGHT CHAIN OF FAB FRAGMENT FROM AN PAI-1 ANTIBODY

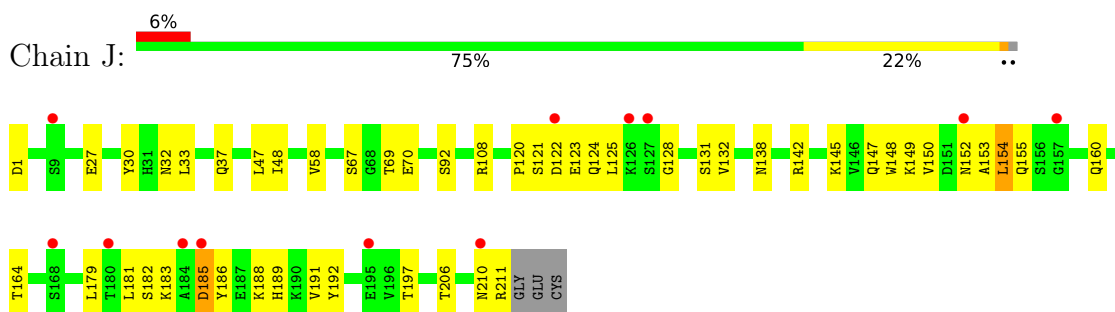

- Molecule 3: LIGHT CHAIN OF FAB FRAGMENT FROM AN PAI-1 ANTIBODY

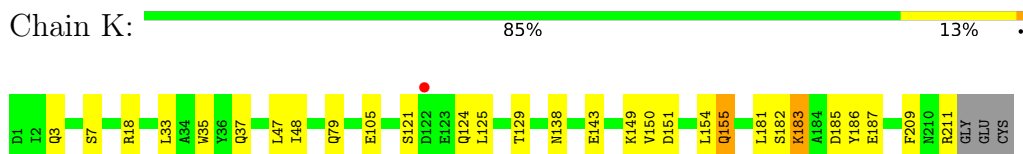

- Molecule 3: LIGHT CHAIN OF FAB FRAGMENT FROM AN PAI-1 ANTIBODY

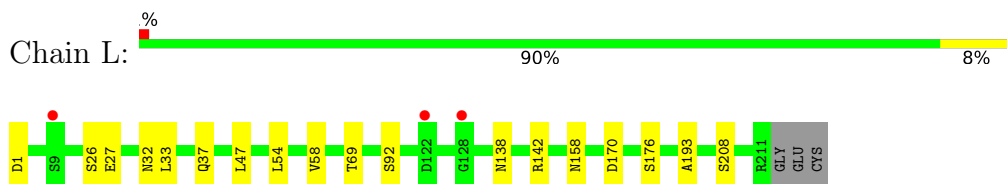

4 Data and refinement statistics

Property	Value	Source
Space group	P 1 21 1	Depositor
Cell constants a, b, c, α , β , γ	90.22Å 89.66Å 249.77Å 90.00° 99.35° 90.00°	Depositor
Resolution (Å)	14.99 – 2.90 14.99 – 2.90	Depositor EDS
% Data completeness (in resolution range)	99.2 (14.99-2.90) 99.2 (14.99-2.90)	Depositor EDS
R_{merge}	0.10	Depositor
R_{sym}	(Not available)	Depositor
$\langle I/\sigma(I) \rangle$ ¹	2.72 (at 2.91Å)	Xtrriage
Refinement program	BUSTER 2.10.0	Depositor
R, R_{free}	0.219 , 0.243 0.229 , 0.253	Depositor DCC
R_{free} test set	4317 reflections (5.00%)	wwPDB-VP
Wilson B-factor (Å ²)	65.0	Xtrriage
Anisotropy	0.068	Xtrriage
Bulk solvent k_{sol} (e/Å ³), B_{sol} (Å ²)	0.34 , 42.2	EDS
L-test for twinning ²	$\langle L \rangle = 0.47$, $\langle L^2 \rangle = 0.29$	Xtrriage
Estimated twinning fraction	0.028 for h,-k,-h-l	Xtrriage
F_o, F_c correlation	0.92	EDS
Total number of atoms	24618	wwPDB-VP
Average B, all atoms (Å ²)	63.0	wwPDB-VP

Xtrriage's analysis on translational NCS is as follows: *The largest off-origin peak in the Patterson function is 2.93% of the height of the origin peak. No significant pseudotranslation is detected.*

¹Intensities estimated from amplitudes.

²Theoretical values of $\langle |L| \rangle$, $\langle L^2 \rangle$ for acentric reflections are 0.5, 0.333 respectively for untwinned datasets, and 0.375, 0.2 for perfectly twinned datasets.

5 Model quality i

5.1 Standard geometry i

The Z score for a bond length (or angle) is the number of standard deviations the observed value is removed from the expected value. A bond length (or angle) with $|Z| > 5$ is considered an outlier worth inspection. RMSZ is the root-mean-square of all Z scores of the bond lengths (or angles).

Mol	Chain	Bond lengths		Bond angles	
		RMSZ	# Z >5	RMSZ	# Z >5
1	A	0.51	1/2971 (0.0%)	0.68	2/4025 (0.0%)
1	B	0.52	0/2971	0.65	0/4025
1	C	0.44	0/2971	0.64	0/4025
1	D	0.47	0/2971	0.68	2/4025 (0.0%)
2	E	0.55	0/1653	0.72	2/2250 (0.1%)
2	F	0.76	0/1653	0.81	0/2250
2	G	0.46	1/1653 (0.1%)	0.63	0/2250
2	H	0.35	0/1653	0.62	0/2250
3	I	0.46	0/1664	0.64	0/2259
3	J	0.47	0/1664	0.66	0/2259
3	K	0.54	0/1664	0.66	0/2259
3	L	0.40	0/1664	0.62	0/2259
All	All	0.50	2/25152 (0.0%)	0.67	6/34136 (0.0%)

Chiral center outliers are detected by calculating the chiral volume of a chiral center and verifying if the center is modelled as a planar moiety or with the opposite hand. A planarity outlier is detected by checking planarity of atoms in a peptide group, atoms in a mainchain group or atoms of a sidechain that are expected to be planar.

Mol	Chain	#Chirality outliers	#Planarity outliers
1	D	0	1

All (2) bond length outliers are listed below:

Mol	Chain	Res	Type	Atoms	Z	Observed(Å)	Ideal(Å)
1	A	220	TYR	CE1-CZ	-5.13	1.31	1.38
2	G	60	TYR	CE1-CZ	-5.01	1.32	1.38

All (6) bond angle outliers are listed below:

Mol	Chain	Res	Type	Atoms	Z	Observed(°)	Ideal(°)
1	A	217	ASP	CB-CG-OD1	7.14	124.73	118.30
1	D	26	ALA	C-N-CA	6.19	137.17	121.70

Continued on next page...

Continued from previous page...

Mol	Chain	Res	Type	Atoms	Z	Observed(°)	Ideal(°)
2	E	120	SER	C-N-CA	5.49	135.42	121.70
1	D	90	GLU	N-CA-C	5.29	125.27	111.00
2	E	15	GLY	C-N-CA	5.16	134.60	121.70
1	A	117	PHE	N-CA-C	5.10	124.76	111.00

There are no chirality outliers.

All (1) planarity outliers are listed below:

Mol	Chain	Res	Type	Group
1	D	88	LYS	Peptide

5.2 Too-close contacts [i](#)

In the following table, the Non-H and H(model) columns list the number of non-hydrogen atoms and hydrogen atoms in the chain respectively. The H(added) column lists the number of hydrogen atoms added and optimized by MolProbity. The Clashes column lists the number of clashes within the asymmetric unit, whereas Symm-Clashes lists symmetry-related clashes.

Mol	Chain	Non-H	H(model)	H(added)	Clashes	Symm-Clashes
1	A	2901	0	2891	26	0
1	B	2901	0	2891	39	0
1	C	2901	0	2891	29	0
1	D	2901	0	2891	58	0
2	E	1614	0	1589	23	0
2	F	1614	0	1589	77	0
2	G	1614	0	1589	10	0
2	H	1614	0	1589	9	0
3	I	1628	0	1591	14	0
3	J	1628	0	1591	43	0
3	K	1628	0	1591	21	0
3	L	1628	0	1591	4	0
4	A	6	0	0	0	0
4	B	5	0	0	0	0
4	C	7	0	0	0	0
4	D	5	0	0	0	0
4	F	2	0	0	0	0
4	H	3	0	0	0	0
4	I	4	0	0	0	0
4	J	3	0	0	0	0
4	K	7	0	0	0	0
4	L	4	0	0	0	0

Continued on next page...

Continued from previous page...

Mol	Chain	Non-H	H(model)	H(added)	Clashes	Symm-Clashes
All	All	24618	0	24284	345	0

The all-atom clashscore is defined as the number of clashes found per 1000 atoms (including hydrogen atoms). The all-atom clashscore for this structure is 7.

All (345) close contacts within the same asymmetric unit are listed below, sorted by their clash magnitude.

Atom-1	Atom-2	Interatomic distance (Å)	Clash overlap (Å)
2:F:203:ILE:HG23	2:F:217:LYS:O	1.44	1.18
2:E:200:GLN:NE2	2:E:201:THR:O	1.88	1.06
1:B:88:LYS:H	1:B:89:ASP:HA	1.28	0.98
3:J:125:LEU:HB3	3:J:183:LYS:HE2	1.46	0.96
1:A:84:GLY:H	1:A:87:ASN:HD21	1.08	0.96
2:F:203:ILE:CG2	2:F:217:LYS:O	2.15	0.95
2:F:179:GLN:OE1	2:F:185:SER:OG	1.85	0.93
1:A:87:ASN:HD22	1:A:87:ASN:H	1.12	0.92
1:C:90:GLU:HG2	1:C:173:GLY:HA2	1.50	0.91
1:C:83:MET:HE1	1:C:93:THR:HG22	1.55	0.89
2:F:153:TYR:CD1	2:F:184:TYR:O	2.25	0.89
1:D:82:LEU:HD11	1:D:371:LEU:HD21	1.52	0.89
3:J:150:VAL:HG13	3:J:191:VAL:O	1.73	0.88
1:C:83:MET:CE	1:C:93:THR:HG22	2.03	0.88
2:F:209:LYS:HG2	2:F:210:PRO:HD3	1.54	0.88
2:F:151:LYS:HG2	2:F:152:ASP:OD1	1.74	0.87
2:F:212:ASN:O	2:F:212:ASN:ND2	2.08	0.87
2:F:151:LYS:HA	2:F:185:SER:HB3	1.57	0.86
2:E:163:ASN:HB3	2:E:166:ALA:HB3	1.58	0.85
3:J:150:VAL:O	3:J:153:ALA:N	2.09	0.85
1:B:90:GLU:HG2	1:B:173:GLY:HA2	1.58	0.84
1:B:88:LYS:HB3	1:B:89:ASP:O	1.76	0.83
2:F:153:TYR:CE2	2:F:158:VAL:HG23	2.13	0.83
1:D:83:MET:HB3	1:D:87:ASN:HB2	1.60	0.83
3:J:150:VAL:HG23	3:J:155:GLN:NE2	1.94	0.82
1:D:83:MET:HG2	1:D:86:TRP:HE1	1.45	0.82
2:F:211:SER:OG	2:F:213:THR:OG1	1.94	0.82
3:K:121:SER:O	3:K:125:LEU:HD12	1.79	0.82
2:F:217:LYS:NZ	3:J:123:GLU:OE2	2.13	0.81
1:D:301:GLN:HG2	1:D:302:PHE:H	1.44	0.81
2:F:168:THR:O	2:F:171:VAL:HG23	1.80	0.81
3:J:125:LEU:HA	3:J:183:LYS:CE	2.11	0.80
1:D:83:MET:HG2	1:D:86:TRP:NE1	1.96	0.80

Continued on next page...

Continued from previous page...

Atom-1	Atom-2	Interatomic distance (Å)	Clash overlap (Å)
2:F:211:SER:HG	2:F:213:THR:HG1	1.20	0.80
2:F:154:PHE:CD1	2:F:155:PRO:HB3	2.17	0.80
2:F:194:SER:O	2:F:197:LEU:HB2	1.82	0.79
2:E:194:SER:O	2:E:197:LEU:HB2	1.83	0.79
3:J:148:TRP:O	3:J:155:GLN:HG2	1.81	0.79
2:F:67:ARG:HH12	2:F:90:ASP:CG	1.86	0.79
2:F:125:LYS:HD2	2:F:183:LEU:HD21	1.65	0.79
3:J:125:LEU:CB	3:J:183:LYS:HE2	2.12	0.77
2:E:200:GLN:HE21	2:E:201:THR:N	1.81	0.77
1:C:87:ASN:C	1:C:89:ASP:HA	2.04	0.77
2:F:154:PHE:CE1	2:F:155:PRO:HB3	2.20	0.77
1:B:78:LEU:O	1:B:82:LEU:HG	1.87	0.75
3:K:149:LYS:HG2	3:K:154:LEU:HD23	1.67	0.74
1:D:301:GLN:HG2	1:D:302:PHE:N	1.99	0.74
3:J:150:VAL:HG23	3:J:155:GLN:HE22	1.52	0.73
1:A:84:GLY:H	1:A:87:ASN:ND2	1.85	0.72
2:F:182:GLY:O	2:F:183:LEU:HD12	1.88	0.72
3:I:121:SER:OG	3:I:124:GLN:HB3	1.90	0.72
2:F:207:ASN:N	2:F:207:ASN:HD22	1.88	0.71
2:F:209:LYS:CG	2:F:210:PRO:HD3	2.21	0.71
1:A:79:TYR:O	1:A:83:MET:HB2	1.90	0.71
2:H:30:SER:HA	2:H:53:PRO:HG2	1.72	0.71
2:G:64:PHE:HB2	2:G:68:VAL:HG12	1.71	0.71
3:J:125:LEU:O	3:J:183:LYS:HE3	1.91	0.71
1:D:83:MET:HG2	1:D:86:TRP:CD1	2.25	0.71
2:F:67:ARG:NH1	2:F:90:ASP:OD2	2.23	0.71
1:C:76:ARG:O	1:C:80:LYS:HG3	1.91	0.71
3:J:185:ASP:OD1	3:J:185:ASP:N	2.20	0.71
1:B:104:LYS:H	1:B:312:GLN:HE21	1.37	0.70
1:D:83:MET:HE2	1:D:86:TRP:HD1	1.55	0.70
2:F:163:ASN:CB	2:F:166:ALA:HB3	2.22	0.69
3:J:125:LEU:HA	3:J:183:LYS:HE3	1.74	0.69
1:B:85:PRO:HB3	1:B:86:TRP:CD1	2.28	0.69
1:D:83:MET:CE	1:D:86:TRP:HD1	2.06	0.69
1:B:100:GLN:OE1	1:B:101:ARG:N	2.25	0.68
2:E:163:ASN:CB	2:E:166:ALA:HB3	2.24	0.68
1:A:87:ASN:H	1:A:87:ASN:ND2	1.90	0.68
3:J:121:SER:OG	3:J:124:GLN:HG3	1.94	0.68
3:I:6:GLN:HE22	3:I:87:TYR:HA	1.60	0.67
1:A:84:GLY:N	1:A:87:ASN:HD21	1.89	0.67
1:B:86:TRP:HA	1:B:86:TRP:CE3	2.30	0.66

Continued on next page...

Continued from previous page...

Atom-1	Atom-2	Interatomic distance (Å)	Clash overlap (Å)
1:A:87:ASN:HD22	1:A:87:ASN:N	1.89	0.66
1:D:57:GLN:OE1	1:D:297:ASP:HB2	1.96	0.66
2:F:203:ILE:HG23	2:F:217:LYS:C	2.16	0.66
2:F:178:LEU:HB2	2:F:184:TYR:CE1	2.31	0.66
3:J:181:LEU:HD22	3:J:185:ASP:HB2	1.78	0.65
1:D:88:LYS:HA	1:D:90:GLU:N	2.12	0.65
1:C:81:GLU:O	1:C:86:TRP:HZ2	1.80	0.65
2:G:64:PHE:CB	2:G:68:VAL:HG12	2.27	0.65
3:J:125:LEU:CA	3:J:183:LYS:CE	2.75	0.65
3:K:149:LYS:HG2	3:K:154:LEU:CD2	2.27	0.65
1:D:88:LYS:HZ1	1:D:145:LYS:HD2	1.61	0.64
1:B:88:LYS:H	1:B:89:ASP:CA	2.06	0.64
1:D:83:MET:HE2	1:D:86:TRP:CD1	2.31	0.64
2:F:163:ASN:HB3	2:F:166:ALA:HB3	1.80	0.64
1:B:185:HIS:HE1	1:B:187:ARG:HE	1.45	0.64
1:C:87:ASN:O	1:C:89:ASP:HA	1.98	0.64
2:F:173:THR:HG23	2:F:188:SER:HB2	1.78	0.64
1:D:83:MET:HB3	1:D:87:ASN:CB	2.28	0.64
3:J:150:VAL:CG1	3:J:191:VAL:O	2.45	0.63
2:G:64:PHE:HB2	2:G:68:VAL:CG1	2.27	0.63
1:B:104:LYS:HB2	1:B:312:GLN:HG2	1.80	0.63
2:F:182:GLY:C	2:F:183:LEU:HD12	2.19	0.63
1:B:88:LYS:HB3	1:B:89:ASP:C	2.18	0.62
2:F:153:TYR:HD1	2:F:184:TYR:O	1.77	0.62
3:J:125:LEU:CA	3:J:183:LYS:HE2	2.29	0.62
2:H:28:THR:HG23	2:H:32:TYR:HE2	1.64	0.62
1:D:33:VAL:HG12	1:D:360:PHE:HZ	1.64	0.62
1:B:85:PRO:HA	1:B:86:TRP:CD2	2.34	0.62
3:K:149:LYS:CG	3:K:154:LEU:HD23	2.28	0.62
1:C:83:MET:HE2	1:C:93:THR:HG22	1.81	0.61
3:K:124:GLN:O	3:K:129:THR:O	2.18	0.61
1:B:89:ASP:OD2	1:B:92:SER:OG	2.19	0.61
2:F:211:SER:CB	2:F:213:THR:HG1	2.13	0.61
1:D:91:ILE:HD12	1:D:92:SER:N	2.16	0.61
1:A:83:MET:CE	1:A:93:THR:HG22	2.30	0.60
1:A:83:MET:HE1	1:A:93:THR:HG22	1.82	0.60
3:K:150:VAL:HG23	3:K:155:GLN:OE1	2.01	0.60
2:E:124:THR:HG23	2:E:155:PRO:HD3	1.83	0.60
3:K:182:SER:OG	3:K:185:ASP:HB2	2.02	0.60
3:J:128:GLY:O	3:J:183:LYS:HG3	2.02	0.60
1:B:88:LYS:N	1:B:89:ASP:HA	2.07	0.59

Continued on next page...

Continued from previous page...

Atom-1	Atom-2	Interatomic distance (Å)	Clash overlap (Å)
1:D:88:LYS:HA	1:D:90:GLU:H	1.67	0.59
2:E:120:SER:HA	2:E:121:SER:HB3	1.84	0.59
3:K:182:SER:O	3:K:185:ASP:N	2.34	0.59
2:E:127:PRO:HB3	2:E:153:TYR:HB3	1.84	0.59
2:E:196:SER:HG	2:E:202:TYR:HH	1.51	0.59
2:F:154:PHE:CD1	2:F:155:PRO:CB	2.85	0.58
1:D:83:MET:CE	1:D:86:TRP:CD1	2.85	0.58
2:F:153:TYR:CE1	2:F:184:TYR:O	2.57	0.58
2:F:154:PHE:CD1	2:F:155:PRO:CA	2.86	0.58
1:D:88:LYS:CE	1:D:145:LYS:HD2	2.34	0.58
2:F:213:THR:HG22	2:F:214:LYS:N	2.19	0.58
3:J:182:SER:OG	3:J:183:LYS:N	2.35	0.57
1:D:87:ASN:HD22	1:D:88:LYS:N	2.02	0.57
1:C:86:TRP:CD1	1:C:86:TRP:N	2.73	0.57
1:D:26:ALA:HB3	1:D:27:SER:HB2	1.87	0.56
3:I:185:ASP:N	3:I:185:ASP:OD1	2.39	0.56
3:I:125:LEU:HD11	3:I:211:ARG:HH22	1.70	0.56
2:F:155:PRO:HD2	2:F:210:PRO:HG2	1.88	0.56
2:F:163:ASN:HB2	2:F:166:ALA:HB3	1.88	0.55
1:C:153:GLY:HA3	1:C:321:LEU:HD11	1.89	0.55
3:I:37:GLN:HB2	3:I:47:LEU:HD11	1.89	0.55
2:F:147:GLY:HA3	2:F:189:VAL:HG12	1.88	0.54
2:F:209:LYS:CG	2:F:210:PRO:CD	2.86	0.54
3:K:183:LYS:O	3:K:186:TYR:HB3	2.07	0.54
2:F:174:PHE:CE1	3:J:164:THR:HG23	2.42	0.54
3:K:149:LYS:CG	3:K:154:LEU:CD2	2.84	0.54
2:F:154:PHE:HD1	2:F:155:PRO:CB	2.20	0.54
1:B:68:ASP:HB2	1:B:71:MET:HG3	1.89	0.54
1:A:251:THR:HA	1:A:254:LEU:HD12	1.89	0.54
2:F:153:TYR:CE2	2:F:158:VAL:CG2	2.87	0.54
3:L:37:GLN:HB2	3:L:47:LEU:HD11	1.89	0.54
2:F:209:LYS:HG3	2:F:210:PRO:N	2.22	0.53
1:A:280:LEU:HD11	1:A:376:VAL:HG22	1.90	0.53
2:F:196:SER:OG	2:F:202:TYR:OH	2.04	0.53
3:J:120:PRO:HD3	3:J:132:VAL:HG22	1.90	0.53
3:K:125:LEU:O	3:K:183:LYS:NZ	2.41	0.53
2:F:154:PHE:HD1	2:F:155:PRO:CA	2.21	0.53
3:K:182:SER:O	3:K:186:TYR:N	2.37	0.53
1:D:76:ARG:HH12	1:D:116:LEU:HA	1.74	0.53
3:I:90:GLN:HE21	3:I:97:THR:H	1.57	0.53
1:D:286:LEU:HD11	1:D:322:GLN:HB2	1.91	0.52

Continued on next page...

Continued from previous page...

Atom-1	Atom-2	Interatomic distance (Å)	Clash overlap (Å)
1:C:48:LEU:HD13	1:C:117:PHE:HE2	1.75	0.52
1:C:280:LEU:HD11	1:C:376:VAL:HG22	1.91	0.52
1:D:88:LYS:NZ	1:D:145:LYS:HD2	2.24	0.52
1:C:88:LYS:N	1:C:89:ASP:CA	2.72	0.52
1:D:65:LYS:HB2	1:D:68:ASP:HB2	1.91	0.52
1:D:87:ASN:ND2	1:D:91:ILE:CG2	2.72	0.52
2:F:153:TYR:CD2	2:F:158:VAL:HG23	2.44	0.52
2:F:214:LYS:C	2:F:215:VAL:HG23	2.30	0.52
1:A:170:TYR:HD1	1:A:325:LYS:HB3	1.75	0.52
1:B:280:LEU:HD11	1:B:376:VAL:HG22	1.91	0.52
3:K:37:GLN:HB2	3:K:47:LEU:HD11	1.91	0.52
1:A:46:LEU:HD13	1:A:165:LEU:HD21	1.91	0.51
2:F:162:TRP:CZ3	2:F:204:CYS:HB3	2.45	0.51
2:F:127:PRO:HB3	2:F:153:TYR:HB3	1.93	0.51
1:D:87:ASN:ND2	1:D:88:LYS:N	2.58	0.51
2:H:4:LEU:HD11	2:H:98:ARG:HB2	1.93	0.51
3:I:35:TRP:HB2	3:I:48:ILE:HB	1.93	0.51
3:K:155:GLN:HA	3:K:155:GLN:HE21	1.75	0.51
2:F:161:SER:HB3	2:F:205:ASN:HB2	1.93	0.51
2:E:120:SER:HA	2:E:121:SER:CB	2.40	0.51
1:D:58:ILE:HA	1:D:295:MET:HE3	1.91	0.50
1:D:88:LYS:HZ1	1:D:145:LYS:CD	2.25	0.50
2:F:179:GLN:HG3	2:F:183:LEU:O	2.11	0.50
3:L:32:ASN:HD22	3:L:92:SER:HA	1.76	0.50
3:L:47:LEU:HA	3:L:58:VAL:HG21	1.93	0.50
2:F:174:PHE:O	2:F:186:LEU:HD13	2.12	0.50
1:D:302:PHE:O	1:D:303:GLN:HB2	2.12	0.50
3:K:35:TRP:HB2	3:K:48:ILE:HB	1.93	0.50
3:J:37:GLN:HB2	3:J:47:LEU:HD11	1.93	0.50
1:C:105:LEU:HD23	1:C:310:SER:HB2	1.94	0.49
3:I:125:LEU:HD11	3:I:211:ARG:NH2	2.26	0.49
3:J:125:LEU:CA	3:J:183:LYS:HE3	2.36	0.49
2:G:1:GLN:HE22	2:G:110:TYR:HE1	1.59	0.49
1:B:88:LYS:N	1:B:89:ASP:CA	2.72	0.49
1:D:51:GLY:HA2	1:D:55:GLN:HE21	1.77	0.49
1:D:87:ASN:ND2	1:D:91:ILE:HG23	2.27	0.49
1:D:183:SER:HB3	1:D:203:ALA:HB3	1.95	0.49
2:F:153:TYR:OH	2:F:186:LEU:HD23	2.12	0.49
1:A:178:PRO:HB3	1:A:331:SER:HB3	1.94	0.49
1:C:137:ASN:HD21	1:C:151:LEU:H	1.59	0.49
2:E:171:VAL:HG22	2:E:190:VAL:HG23	1.94	0.49

Continued on next page...

Continued from previous page...

Atom-1	Atom-2	Interatomic distance (Å)	Clash overlap (Å)
1:D:82:LEU:HG	1:D:82:LEU:O	2.13	0.49
3:J:125:LEU:HA	3:J:183:LYS:HE2	1.88	0.49
2:E:162:TRP:CE2	2:E:204:CYS:HB3	2.48	0.49
1:B:153:GLY:HA3	1:B:321:LEU:HD11	1.94	0.49
1:C:82:LEU:HD22	1:C:371:LEU:HD21	1.93	0.49
2:F:148:CYS:HB2	2:F:162:TRP:CH2	2.48	0.48
3:I:122:ASP:OD1	3:I:126:LYS:HE3	2.12	0.48
1:A:127:SER:HA	1:A:159:GLN:HG2	1.95	0.48
1:D:79:TYR:HA	1:D:82:LEU:O	2.13	0.48
1:D:137:ASN:HD21	1:D:151:LEU:H	1.60	0.48
2:E:174:PHE:CD1	3:I:164:THR:HG23	2.48	0.48
2:F:154:PHE:CD1	2:F:155:PRO:HA	2.48	0.48
1:B:212:GLU:HB2	3:J:30:TYR:HE1	1.78	0.48
2:F:174:PHE:CD1	3:J:164:THR:HG23	2.49	0.48
3:J:149:LYS:HG2	3:J:154:LEU:HD23	1.94	0.48
3:J:210:ASN:O	3:J:211:ARG:HB2	2.14	0.48
3:J:188:LYS:HD3	3:J:189:HIS:CE1	2.49	0.48
2:F:91:THR:HG23	2:F:118:THR:HA	1.96	0.48
1:C:207:LYS:HB3	1:C:268:ARG:HG2	1.96	0.48
1:D:88:LYS:CA	1:D:90:GLU:H	2.26	0.48
1:A:69:LYS:HA	1:A:70:GLY:HA2	1.71	0.48
1:D:88:LYS:HZ1	1:D:145:LYS:CE	2.26	0.48
2:F:193:PRO:HB2	2:F:196:SER:HB3	1.96	0.48
1:C:88:LYS:N	1:C:89:ASP:HA	2.30	0.47
3:J:47:LEU:HA	3:J:58:VAL:HG21	1.95	0.47
1:A:110:MET:HE1	1:A:121:VAL:H	1.79	0.47
1:B:212:GLU:HB2	3:J:30:TYR:CE1	2.49	0.47
1:C:164:VAL:HG22	1:C:319:LEU:HB3	1.97	0.47
2:F:207:ASN:N	2:F:207:ASN:ND2	2.60	0.47
1:D:172:ASN:HD21	1:D:329:ASN:HD21	1.62	0.47
2:G:211:SER:HG	2:G:213:THR:HG1	1.62	0.47
3:K:149:LYS:HE2	3:K:154:LEU:HD21	1.95	0.47
2:G:150:VAL:HB	2:G:186:LEU:HB3	1.97	0.47
1:D:361:VAL:HG13	1:D:370:VAL:HG13	1.96	0.47
2:E:62:GLN:HA	2:E:65:GLN:HG3	1.97	0.47
1:A:82:LEU:O	1:A:86:TRP:CZ2	2.68	0.47
2:G:91:THR:HG23	2:G:118:THR:HA	1.96	0.46
1:B:161:THR:HG23	1:B:318:ALA:HB3	1.97	0.46
1:D:190:HIS:N	1:D:355:ASP:O	2.45	0.46
2:F:167:LEU:HD13	2:F:190:VAL:HG21	1.98	0.46
1:D:88:LYS:HE3	1:D:145:LYS:HD2	1.98	0.46

Continued on next page...

Continued from previous page...

Atom-1	Atom-2	Interatomic distance (Å)	Clash overlap (Å)
3:L:193:ALA:HB2	3:L:208:SER:HB3	1.97	0.46
1:D:89:ASP:HB3	1:D:90:GLU:HG3	1.97	0.46
2:F:208:HIS:HD2	2:F:211:SER:OG	1.99	0.46
1:A:82:LEU:C	1:A:86:TRP:CZ2	2.89	0.46
1:B:85:PRO:HA	1:B:86:TRP:CE3	2.51	0.45
2:F:162:TRP:CH2	2:F:204:CYS:HB3	2.50	0.45
1:C:95:ASP:HB3	1:C:167:ASN:HD22	1.80	0.45
1:D:91:ILE:HD12	1:D:92:SER:H	1.82	0.45
3:K:181:LEU:HD22	3:K:185:ASP:HB3	1.98	0.45
1:C:103:LEU:HD12	1:C:103:LEU:HA	1.78	0.45
1:D:79:TYR:O	1:D:79:TYR:CD1	2.69	0.45
2:E:143:THR:N	2:E:194:SER:HG	2.14	0.45
2:E:15:GLY:CA	2:E:16:SER:HB2	2.46	0.45
1:A:100:GLN:HB3	1:A:103:LEU:HB2	1.97	0.45
1:C:201:MET:HA	1:C:276:PRO:HA	1.99	0.45
1:B:104:LYS:H	1:B:312:GLN:NE2	2.11	0.45
1:A:30:ARG:HH21	1:B:185:HIS:HB2	1.81	0.45
3:J:124:GLN:HE22	3:J:131:SER:HB2	1.81	0.45
2:E:152:ASP:HB3	2:E:183:LEU:HD13	1.98	0.45
1:A:27:SER:HB3	1:A:30:ARG:HB2	1.99	0.44
1:A:82:LEU:O	1:A:86:TRP:CH2	2.70	0.44
1:B:251:THR:HA	1:B:254:LEU:HD12	1.99	0.44
1:D:78:LEU:O	1:D:82:LEU:HD23	2.17	0.44
2:H:51:ILE:HD12	2:H:58:ALA:HB2	1.99	0.44
1:B:84:GLY:O	1:B:86:TRP:CE3	2.70	0.44
1:C:28:LYS:HA	1:C:375:GLN:HE22	1.82	0.44
2:F:98:ARG:NH1	2:F:99:GLU:O	2.50	0.44
3:K:155:GLN:HE21	3:K:155:GLN:CA	2.30	0.44
1:B:361:VAL:HG13	1:B:370:VAL:HG13	2.00	0.44
2:G:150:VAL:HG11	2:G:158:VAL:HG11	1.99	0.44
1:C:167:ASN:O	1:C:322:GLN:HA	2.18	0.44
1:A:140:VAL:HG21	1:A:151:LEU:HD11	1.99	0.43
1:D:87:ASN:ND2	1:D:91:ILE:HG22	2.33	0.43
2:E:30:SER:HA	2:E:53:PRO:HB2	2.00	0.43
2:F:182:GLY:C	2:F:183:LEU:CD1	2.85	0.43
2:F:177:VAL:HG11	3:J:160:GLN:HB3	2.00	0.43
1:D:58:ILE:HA	1:D:295:MET:CE	2.48	0.43
2:F:38:ARG:HB3	2:F:48:MET:HE2	2.00	0.43
2:F:97:ALA:HB1	2:F:108:PHE:HB3	2.01	0.43
1:B:91:ILE:HB	1:B:171:PHE:HD1	1.82	0.43
2:H:201:THR:HG23	2:H:218:LYS:HE2	2.00	0.43

Continued on next page...

Continued from previous page...

Atom-1	Atom-2	Interatomic distance (Å)	Clash overlap (Å)
2:E:150:VAL:HB	2:E:186:LEU:HB3	2.01	0.43
1:C:96:ALA:HB1	1:C:122:LYS:HD3	2.01	0.43
2:F:209:LYS:O	2:F:212:ASN:N	2.52	0.43
1:C:88:LYS:N	1:C:89:ASP:C	2.71	0.43
3:I:47:LEU:HA	3:I:58:VAL:HG21	2.00	0.43
3:J:186:TYR:CD1	3:J:192:TYR:CZ	3.07	0.43
1:A:90:GLU:OE2	1:A:229:HIS:NE2	2.43	0.43
1:B:83:MET:O	1:B:83:MET:HG3	2.19	0.43
1:B:85:PRO:HA	1:B:86:TRP:HA	1.66	0.43
1:D:251:THR:HA	1:D:254:LEU:HD12	1.99	0.43
2:E:91:THR:HG23	2:E:118:THR:HA	2.00	0.42
3:J:32:ASN:HD22	3:J:92:SER:HA	1.84	0.42
2:F:215:VAL:HG12	2:F:216:ASP:N	2.32	0.42
2:H:38:ARG:HB3	2:H:48:MET:HE2	2.00	0.42
1:B:85:PRO:HA	1:B:86:TRP:CG	2.54	0.42
2:F:197:LEU:HD23	2:F:197:LEU:HA	1.90	0.42
1:B:286:LEU:HD11	1:B:322:GLN:HB2	2.01	0.42
3:J:128:GLY:O	3:J:183:LYS:CG	2.65	0.42
1:D:188:LEU:HD22	1:D:196:THR:HB	2.01	0.42
2:F:60:TYR:HB2	2:F:65:GLN:HG3	2.01	0.42
2:F:213:THR:CG2	2:F:214:LYS:N	2.82	0.42
1:B:83:MET:N	1:B:84:GLY:HA3	2.35	0.42
1:C:58:ILE:O	1:C:62:MET:HB2	2.20	0.42
2:E:51:ILE:HD12	2:E:58:ALA:HB2	2.02	0.42
1:C:362:VAL:HB	1:C:372:PHE:HB2	2.01	0.41
2:F:209:LYS:HG3	2:F:210:PRO:CD	2.49	0.41
3:J:147:GLN:HE21	3:J:154:LEU:HD22	1.85	0.41
1:B:85:PRO:HB3	1:B:86:TRP:NE1	2.33	0.41
1:B:169:LEU:HB2	1:B:324:VAL:HG22	2.02	0.41
1:D:236:PHE:O	1:D:360:PHE:HA	2.21	0.41
2:H:154:PHE:HB2	2:H:183:LEU:HD23	2.01	0.41
1:B:46:LEU:HD13	1:B:165:LEU:HD11	2.01	0.41
1:D:33:VAL:HG11	1:D:326:ILE:HG22	2.01	0.41
3:J:188:LYS:HD3	3:J:189:HIS:HE1	1.85	0.41
2:H:176:ALA:HA	2:H:186:LEU:HB3	2.01	0.41
2:F:209:LYS:CG	2:F:210:PRO:N	2.83	0.41
3:I:6:GLN:HE21	3:I:99:GLY:HA3	1.85	0.41
1:B:104:LYS:O	1:B:310:SER:OG	2.26	0.41
2:F:154:PHE:HA	2:F:155:PRO:HA	1.79	0.41
3:I:125:LEU:O	3:I:183:LYS:HD2	2.21	0.41
3:J:150:VAL:C	3:J:152:ASN:N	2.73	0.41

Continued on next page...

Continued from previous page...

Atom-1	Atom-2	Interatomic distance (Å)	Clash overlap (Å)
1:D:82:LEU:HA	1:D:83:MET:HA	1.86	0.41
1:D:179:PHE:CD2	1:D:202:MET:HB3	2.55	0.41
3:J:183:LYS:HB3	3:J:183:LYS:NZ	2.35	0.41
2:F:163:ASN:O	2:F:164:SER:HB2	2.20	0.41
2:G:64:PHE:HB2	2:G:65:GLN:H	1.69	0.41
2:E:197:LEU:HD23	2:E:197:LEU:HA	1.77	0.41
2:F:203:ILE:HG22	2:F:204:CYS:N	2.34	0.41
2:G:30:SER:HA	2:G:53:PRO:HB2	2.03	0.41
3:K:183:LYS:HA	3:K:186:TYR:HB3	2.02	0.41
1:B:44:ALA:HB1	1:B:66:ILE:HD13	2.02	0.41
1:D:89:ASP:CB	1:D:174:GLN:NE2	2.84	0.41
1:C:83:MET:HE2	1:C:93:THR:CG2	2.49	0.40
1:D:83:MET:HE1	1:D:233:LEU:HG	2.03	0.40
2:H:99:GLU:HG2	2:H:107:HIS:O	2.21	0.40
2:F:162:TRP:CD1	2:F:171:VAL:CG1	3.05	0.40
3:J:148:TRP:CE2	3:J:179:LEU:HB2	2.57	0.40
2:E:167:LEU:HD13	2:E:190:VAL:HG21	2.04	0.40
3:J:150:VAL:O	3:J:153:ALA:HB3	2.21	0.40
3:K:181:LEU:HD23	3:K:181:LEU:HA	1.76	0.40
1:A:44:ALA:HB1	1:A:66:ILE:HD13	2.02	0.40
1:D:100:GLN:HE22	1:D:125:ASP:HA	1.87	0.40
3:I:182:SER:OG	3:I:185:ASP:OD1	2.38	0.40
1:D:302:PHE:O	1:D:303:GLN:CB	2.69	0.40
3:J:145:LYS:HB3	3:J:197:THR:HB	2.03	0.40
3:K:155:GLN:H	3:K:155:GLN:HG2	1.71	0.40

There are no symmetry-related clashes.

5.3 Torsion angles

5.3.1 Protein backbone

In the following table, the Percentiles column shows the percent Ramachandran outliers of the chain as a percentile score with respect to all X-ray entries followed by that with respect to entries of similar resolution.

The Analysed column shows the number of residues for which the backbone conformation was analysed, and the total number of residues.

Mol	Chain	Analysed	Favoured	Allowed	Outliers	Percentiles
1	A	359/379 (95%)	345 (96%)	14 (4%)	0	100 100

Continued on next page...

Continued from previous page...

Mol	Chain	Analysed	Favoured	Allowed	Outliers	Percentiles	
1	B	359/379 (95%)	345 (96%)	14 (4%)	0	100	100
1	C	359/379 (95%)	347 (97%)	11 (3%)	1 (0%)	41	71
1	D	359/379 (95%)	345 (96%)	10 (3%)	4 (1%)	14	42
2	E	210/223 (94%)	200 (95%)	8 (4%)	2 (1%)	15	45
2	F	210/223 (94%)	199 (95%)	11 (5%)	0	100	100
2	G	210/223 (94%)	197 (94%)	11 (5%)	2 (1%)	15	45
2	H	210/223 (94%)	200 (95%)	9 (4%)	1 (0%)	29	61
3	I	209/214 (98%)	198 (95%)	10 (5%)	1 (0%)	29	61
3	J	209/214 (98%)	193 (92%)	15 (7%)	1 (0%)	29	61
3	K	209/214 (98%)	193 (92%)	13 (6%)	3 (1%)	11	36
3	L	209/214 (98%)	199 (95%)	9 (4%)	1 (0%)	29	61
All	All	3112/3264 (95%)	2961 (95%)	135 (4%)	16 (0%)	29	61

All (16) Ramachandran outliers are listed below:

Mol	Chain	Res	Type
2	E	124	THR
1	D	88	LYS
1	D	303	GLN
2	G	28	THR
3	J	138	ASN
3	K	138	ASN
2	G	152	ASP
3	I	138	ASN
3	K	151	ASP
3	L	138	ASN
2	E	16	SER
1	C	102	ASP
1	D	27	SER
3	K	143	GLU
1	D	129	VAL
2	H	155	PRO

5.3.2 Protein sidechains [i](#)

In the following table, the Percentiles column shows the percent sidechain outliers of the chain as a percentile score with respect to all X-ray entries followed by that with respect to entries of similar resolution.

The Analysed column shows the number of residues for which the sidechain conformation was analysed, and the total number of residues.

Mol	Chain	Analysed	Rotameric	Outliers	Percentiles	
1	A	319/333 (96%)	295 (92%)	24 (8%)	13	37
1	B	319/333 (96%)	298 (93%)	21 (7%)	16	44
1	C	319/333 (96%)	294 (92%)	25 (8%)	12	34
1	D	319/333 (96%)	294 (92%)	25 (8%)	12	34
2	E	179/186 (96%)	167 (93%)	12 (7%)	16	43
2	F	179/186 (96%)	164 (92%)	15 (8%)	11	31
2	G	179/186 (96%)	166 (93%)	13 (7%)	14	38
2	H	179/186 (96%)	168 (94%)	11 (6%)	18	48
3	I	185/187 (99%)	175 (95%)	10 (5%)	22	54
3	J	185/187 (99%)	172 (93%)	13 (7%)	15	41
3	K	185/187 (99%)	174 (94%)	11 (6%)	19	49
3	L	185/187 (99%)	175 (95%)	10 (5%)	22	54
All	All	2732/2824 (97%)	2542 (93%)	190 (7%)	15	41

All (190) residues with a non-rotameric sidechain are listed below:

Mol	Chain	Res	Type
1	A	43	LEU
1	A	47	GLN
1	A	48	LEU
1	A	67	ASP
1	A	68	ASP
1	A	71	MET
1	A	83	MET
1	A	87	ASN
1	A	92	SER
1	A	107	GLN
1	A	110	MET
1	A	122	LYS
1	A	130	GLU
1	A	158	ASP
1	A	165	LEU
1	A	182	SER
1	A	209	ASN
1	A	216	PRO
1	A	217	ASP

Continued on next page...

Continued from previous page...

Mol	Chain	Res	Type
1	A	224	LEU
1	A	250	LEU
1	A	325	LYS
1	A	329	ASN
1	A	346	ARG
1	B	14	ASP
1	B	43	LEU
1	B	47	GLN
1	B	78	LEU
1	B	80	LYS
1	B	86	TRP
1	B	89	ASP
1	B	90	GLU
1	B	95	ASP
1	B	104	LYS
1	B	107	GLN
1	B	131	ARG
1	B	141	LYS
1	B	148	ILE
1	B	181	ASP
1	B	217	ASP
1	B	224	LEU
1	B	248	SER
1	B	250	LEU
1	B	293	LEU
1	B	346	ARG
1	C	21	GLN
1	C	25	GLN
1	C	48	LEU
1	C	62	MET
1	C	68	ASP
1	C	69	LYS
1	C	86	TRP
1	C	95	ASP
1	C	102	ASP
1	C	130	GLU
1	C	137	ASN
1	C	145	LYS
1	C	165	LEU
1	C	181	ASP
1	C	186	ARG
1	C	217	ASP

Continued on next page...

Continued from previous page...

Mol	Chain	Res	Type
1	C	224	LEU
1	C	231	ASP
1	C	232	THR
1	C	234	SER
1	C	250	LEU
1	C	257	GLN
1	C	260	SER
1	C	279	SER
1	C	346	ARG
1	D	14	ASP
1	D	42	VAL
1	D	43	LEU
1	D	69	LYS
1	D	78	LEU
1	D	80	LYS
1	D	81	GLU
1	D	82	LEU
1	D	83	MET
1	D	86	TRP
1	D	87	ASN
1	D	88	LYS
1	D	99	VAL
1	D	102	ASP
1	D	137	ASN
1	D	138	ASP
1	D	158	ASP
1	D	167	ASN
1	D	202	MET
1	D	217	ASP
1	D	224	LEU
1	D	250	LEU
1	D	263	LYS
1	D	308	SER
1	D	371	LEU
2	E	19	LYS
2	E	99	GLU
2	E	105	GLU
2	E	123	SER
2	E	168	THR
2	E	196	SER
2	E	200	GLN
2	E	205	ASN

Continued on next page...

Continued from previous page...

Mol	Chain	Res	Type
2	E	213	THR
2	E	217	LYS
2	E	220	GLU
2	E	222	LYS
2	F	10	GLU
2	F	43	GLN
2	F	105	GLU
2	F	154	PHE
2	F	178	LEU
2	F	181	SER
2	F	185	SER
2	F	186	LEU
2	F	194	SER
2	F	195	SER
2	F	199	THR
2	F	201	THR
2	F	207	ASN
2	F	214	LYS
2	F	220	GLU
2	G	1	GLN
2	G	10	GLU
2	G	64	PHE
2	G	67	ARG
2	G	68	VAL
2	G	81	MET
2	G	99	GLU
2	G	148	CYS
2	G	156	GLN
2	G	167	LEU
2	G	217	LYS
2	G	218	LYS
2	G	222	LYS
2	H	10	GLU
2	H	81	MET
2	H	87	ARG
2	H	98	ARG
2	H	99	GLU
2	H	104	LEU
2	H	105	GLU
2	H	148	CYS
2	H	167	LEU
2	H	204	CYS

Continued on next page...

Continued from previous page...

Mol	Chain	Res	Type
2	H	207	ASN
3	I	1	ASP
3	I	7	SER
3	I	33	LEU
3	I	47	LEU
3	I	125	LEU
3	I	126	LYS
3	I	127	SER
3	I	181	LEU
3	I	183	LYS
3	I	185	ASP
3	J	1	ASP
3	J	27	GLU
3	J	33	LEU
3	J	48	ILE
3	J	67	SER
3	J	69	THR
3	J	70	GLU
3	J	108	ARG
3	J	122	ASP
3	J	142	ARG
3	J	154	LEU
3	J	185	ASP
3	J	206	THR
3	K	3	GLN
3	K	7	SER
3	K	18	ARG
3	K	33	LEU
3	K	79	GLN
3	K	105	GLU
3	K	155	GLN
3	K	183	LYS
3	K	187	GLU
3	K	209	PHE
3	K	211	ARG
3	L	1	ASP
3	L	26	SER
3	L	27	GLU
3	L	33	LEU
3	L	54	LEU
3	L	69	THR
3	L	142	ARG

Continued on next page...

Continued from previous page...

Mol	Chain	Res	Type
3	L	158	ASN
3	L	170	ASP
3	L	176	SER

Sometimes sidechains can be flipped to improve hydrogen bonding and reduce clashes. All (42) such sidechains are listed below:

Mol	Chain	Res	Type
1	A	87	ASN
1	A	159	GLN
1	A	174	GLN
1	A	329	ASN
1	A	365	ASN
1	B	56	GLN
1	B	150	HIS
1	B	185	HIS
1	B	261	HIS
1	B	312	GLN
1	C	137	ASN
1	C	257	GLN
1	C	301	GLN
1	D	55	GLN
1	D	59	GLN
1	D	87	ASN
1	D	100	GLN
1	D	112	HIS
1	D	137	ASN
1	D	172	ASN
1	D	174	GLN
2	E	156	GLN
2	E	172	HIS
2	E	179	GLN
2	E	200	GLN
2	E	207	ASN
2	E	208	HIS
2	F	102	GLN
2	F	207	ASN
2	F	208	HIS
2	G	1	GLN
2	G	179	GLN
2	G	208	HIS
2	H	207	ASN
2	H	208	HIS

Continued on next page...

Continued from previous page...

Mol	Chain	Res	Type
3	I	6	GLN
3	I	90	GLN
3	I	137	ASN
3	J	147	GLN
3	J	155	GLN
3	L	32	ASN
3	L	189	HIS

5.3.3 RNA [i](#)

There are no RNA molecules in this entry.

5.4 Non-standard residues in protein, DNA, RNA chains [i](#)

There are no non-standard protein/DNA/RNA residues in this entry.

5.5 Carbohydrates [i](#)

There are no monosaccharides in this entry.

5.6 Ligand geometry [i](#)

There are no ligands in this entry.

5.7 Other polymers [i](#)

There are no such residues in this entry.

5.8 Polymer linkage issues [i](#)

There are no chain breaks in this entry.

6 Fit of model and data

6.1 Protein, DNA and RNA chains

In the following table, the column labelled ‘#RSRZ > 2’ contains the number (and percentage) of RSRZ outliers, followed by percent RSRZ outliers for the chain as percentile scores relative to all X-ray entries and entries of similar resolution. The OWAB column contains the minimum, median, 95th percentile and maximum values of the occupancy-weighted average B-factor per residue. The column labelled ‘Q < 0.9’ lists the number of (and percentage) of residues with an average occupancy less than 0.9.

Mol	Chain	Analysed	<RSRZ>	#RSRZ>2	OWAB(Å ²)	Q<0.9
1	A	363/379 (95%)	0.01	12 (3%) 46 41	34, 49, 73, 83	0
1	B	363/379 (95%)	0.17	18 (4%) 28 25	37, 53, 85, 99	0
1	C	363/379 (95%)	0.18	14 (3%) 39 35	44, 62, 88, 98	0
1	D	363/379 (95%)	0.46	39 (10%) 6 4	54, 72, 113, 127	0
2	E	214/223 (95%)	0.52	14 (6%) 18 14	52, 77, 109, 122	0
2	F	214/223 (95%)	0.45	14 (6%) 18 14	49, 75, 104, 121	0
2	G	214/223 (95%)	0.13	6 (2%) 53 49	44, 61, 83, 97	0
2	H	214/223 (95%)	0.25	11 (5%) 28 24	44, 63, 80, 90	0
3	I	211/214 (98%)	0.11	4 (1%) 66 65	37, 56, 82, 92	0
3	J	211/214 (98%)	0.30	12 (5%) 23 19	41, 57, 116, 130	0
3	K	211/214 (98%)	0.04	1 (0%) 91 91	32, 47, 97, 110	0
3	L	211/214 (98%)	-0.08	3 (1%) 75 75	35, 44, 74, 86	0
All	All	3152/3264 (96%)	0.21	148 (4%) 31 28	32, 61, 99, 130	0

All (148) RSRZ outliers are listed below:

Mol	Chain	Res	Type	RSRZ
2	F	212	ASN	5.5
1	D	70	GLY	5.0
1	D	150	HIS	4.9
3	J	157	GLY	4.9
1	C	67	ASP	4.5
1	C	85	PRO	4.4
1	D	333	THR	4.3
3	J	152	ASN	4.2
1	C	333	THR	4.1
1	C	345	ALA	4.1
1	D	301	GLN	4.1

Continued on next page...

Continued from previous page...

Mol	Chain	Res	Type	RSRZ
2	H	27	GLY	4.1
1	D	107	GLN	4.0
3	L	122	ASP	4.0
1	B	77	HIS	3.9
1	D	89	ASP	3.8
3	J	122	ASP	3.8
2	F	199	THR	3.7
3	J	127	SER	3.7
1	D	156	ALA	3.6
1	C	6	SER	3.6
1	D	69	LYS	3.6
3	J	168	SER	3.4
1	D	77	HIS	3.4
1	A	107	GLN	3.4
2	F	27	GLY	3.4
1	D	56	GLN	3.4
1	C	150	HIS	3.4
2	F	125	LYS	3.3
2	G	75	SER	3.3
1	D	303	GLN	3.2
1	C	346	ARG	3.2
2	G	221	PRO	3.1
3	L	9	SER	3.1
2	E	165	GLY	3.1
2	E	195	SER	3.0
1	D	85	PRO	3.0
3	J	184	ALA	3.0
1	D	312	GLN	3.0
2	G	65	GLN	2.9
1	B	102	ASP	2.9
2	F	127	PRO	2.9
1	B	302	PHE	2.9
2	E	62	GLN	2.9
1	B	311	ASP	2.9
2	E	199	THR	2.8
2	F	168	THR	2.8
3	J	185	ASP	2.8
1	B	107	GLN	2.8
2	E	221	PRO	2.8
2	F	180	SER	2.8
1	D	7	TYR	2.7
1	D	112	HIS	2.7

Continued on next page...

Continued from previous page...

Mol	Chain	Res	Type	RSRZ
1	B	345	ALA	2.7
2	E	166	ALA	2.7
2	H	65	GLN	2.7
2	E	203	ILE	2.7
1	A	67	ASP	2.7
1	B	89	ASP	2.7
1	B	131	ARG	2.7
2	E	212	ASN	2.7
1	D	307	THR	2.6
1	B	101	ARG	2.6
2	F	152	ASP	2.6
1	D	281	GLU	2.6
1	C	115	ARG	2.6
2	E	194	SER	2.6
1	B	150	HIS	2.6
1	D	302	PHE	2.6
1	B	130	GLU	2.5
2	F	1	GLN	2.5
1	D	300	ARG	2.5
1	D	160	LEU	2.5
2	H	62	GLN	2.5
2	E	201	THR	2.5
1	D	345	ALA	2.5
1	C	73	PRO	2.5
1	D	88	LYS	2.5
1	B	301	GLN	2.5
2	H	1	GLN	2.5
1	B	127	SER	2.5
1	D	127	SER	2.5
2	E	159	THR	2.5
1	D	162	ARG	2.4
2	H	89	GLU	2.4
1	A	88	LYS	2.4
2	G	57	THR	2.4
1	C	108	GLY	2.4
1	D	63	GLY	2.4
2	E	121	SER	2.4
3	I	188	LYS	2.4
2	E	180	SER	2.4
1	D	287	ARG	2.4
3	J	126	LYS	2.4
2	E	168	THR	2.4

Continued on next page...

Continued from previous page...

Mol	Chain	Res	Type	RSRZ
1	D	102	ASP	2.4
2	G	88	SER	2.4
1	D	71	MET	2.3
1	C	7	TYR	2.3
1	B	152	LEU	2.3
1	C	231	ASP	2.3
1	D	125	ASP	2.3
1	A	230	GLY	2.3
1	D	155	GLY	2.3
1	B	128	GLU	2.3
1	D	83	MET	2.3
2	F	126	GLY	2.3
1	B	86	TRP	2.3
1	B	88	LYS	2.3
2	F	181	SER	2.3
1	C	89	ASP	2.2
2	G	76	THR	2.2
1	A	231	ASP	2.2
2	F	216	ASP	2.2
1	C	186	ARG	2.2
1	D	120	THR	2.2
2	H	199	THR	2.2
3	L	128	GLY	2.2
1	D	60	ALA	2.2
1	A	301	GLN	2.2
2	F	153	TYR	2.2
2	H	212	ASN	2.2
2	H	57	THR	2.2
1	D	28	LYS	2.2
2	F	222	LYS	2.2
1	A	7	TYR	2.2
1	D	138	ASP	2.1
1	A	85	PRO	2.1
2	H	56	GLY	2.1
1	A	302	PHE	2.1
1	A	345	ALA	2.1
1	D	314	PRO	2.1
3	J	9	SER	2.1
3	I	143	GLU	2.1
3	J	180	THR	2.1
1	D	119	SER	2.1
3	K	122	ASP	2.1

Continued on next page...

Continued from previous page...

Mol	Chain	Res	Type	RSRZ
2	H	15	GLY	2.1
1	A	150	HIS	2.0
1	B	160	LEU	2.0
3	I	125	LEU	2.0
1	A	89	ASP	2.0
3	I	157	GLY	2.0
1	D	139	TRP	2.0
3	J	210	ASN	2.0
1	D	230	GLY	2.0
2	H	26	GLY	2.0
3	J	195	GLU	2.0

6.2 Non-standard residues in protein, DNA, RNA chains [i](#)

There are no non-standard protein/DNA/RNA residues in this entry.

6.3 Carbohydrates [i](#)

There are no monosaccharides in this entry.

6.4 Ligands [i](#)

There are no ligands in this entry.

6.5 Other polymers [i](#)

There are no such residues in this entry.